

LID KEY	
1	BLACK COLOR

DFWB9C-1-LID

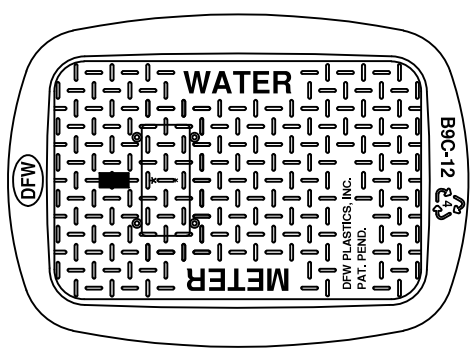

DFWB9C-12-1

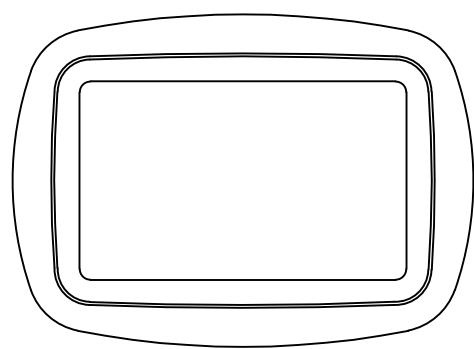
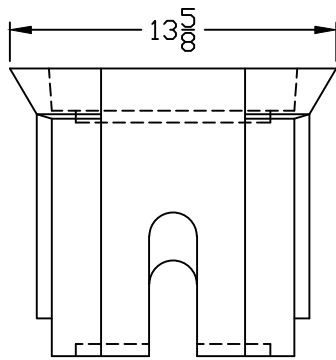
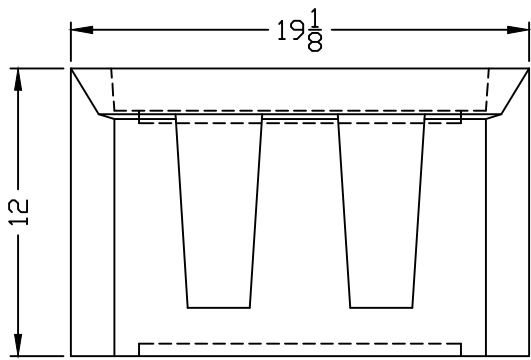

DFWB9C-12-BODY

NOTES

- 1) DIM'S ± 1/8" U.N.O.
- 2) LID MATERIAL: HDPE
- 3) BODY MATERIAL: LLDPE
- 4) WALL THICKNESS: 3/8" ± 5%
- 5) I.W.A. = INSIDE WORK AREA

DFW PLASTICS, INC. ENGAGES IN ONGOING RESEARCH AND DEVELOPMENT TO IMPROVE AND ENHANCE ITS PRODUCTS. THEREFORE, DFW PLASTICS, INC. RESERVES THE RIGHT TO CHANGE PRODUCT OR SYSTEM SPECIFICATIONS WITHOUT NOTICE.



DFW PLASTICS, INC.
 PO BOX 648
 BEDFORD, TEXAS 76095
 (817) 439-3600
 (817) 439-3700 (f)
 www.dfwplasticsinc.com

DFWB9C-12-1

CREATED: 06/01/2011
UPDATED: 03/31/2014
ACCEPTED: JMc
DRAWN BY: RMc
PLOT SCALE: 1:8