

LID KEY	
1	BLACK COLOR

DFWA1C-1-LID

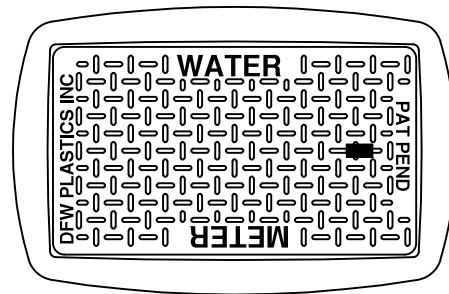

DFWA1C-12-1

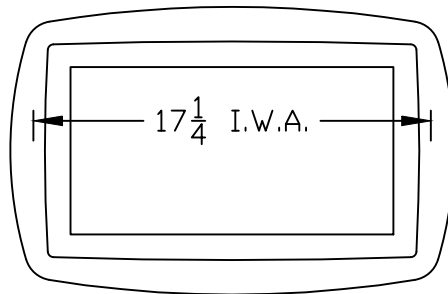
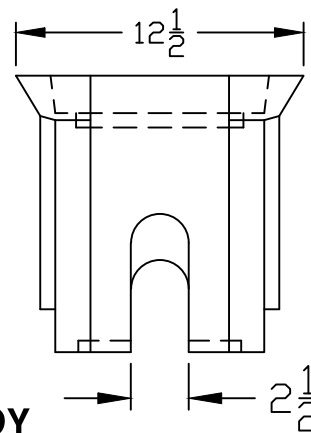
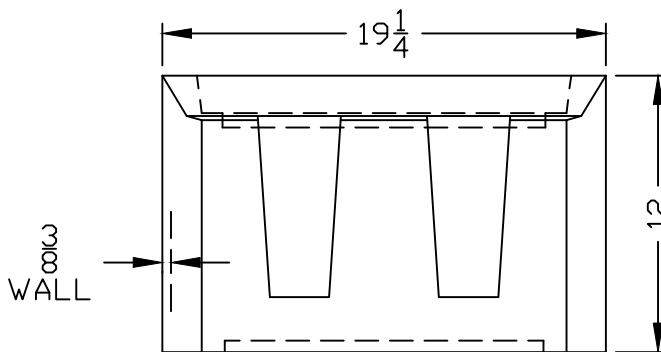

DFWA1C-12-BODY

NOTES

- 1) DIM'S ± 1/8" U.N.O.
- 2) LID MATERIAL: HDPE
- 3) BODY MATERIAL: LLDPE
- 4) WALL THICKNESS: 3/8" ± 5%
- 5) I.W.A. = INSIDE WORK AREA

DFW PLASTICS, INC. ENGAGES IN ONGOING RESEARCH AND DEVELOPMENT TO IMPROVE AND ENHANCE ITS PRODUCTS. THEREFORE, DFW PLASTICS, INC. RESERVES THE RIGHT TO CHANGE PRODUCT OR SYSTEM SPECIFICATIONS WITHOUT NOTICE.



DFW PLASTICS, INC.
 PO BOX 648
 BEDFORD, TEXAS 76095
 (817) 439-3600
 (817) 439-3700 (f)
 www.dfwplasticsinc.com

DFWA1C-12-1

CREATED: 03/29/2013

UPDATED: 03/29/2013

ACCEPTED: JMc

DRAWN BY: RMc

PLOT SCALE: 1:8