

AMR
MOUNT
HOLES

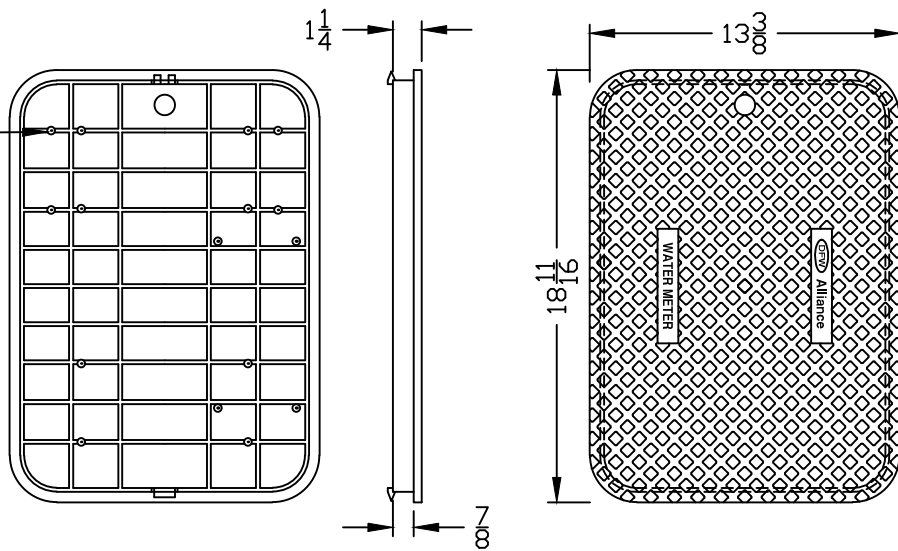

LID KEY	
1	BLACK COLOR

DFW1500.1.LID

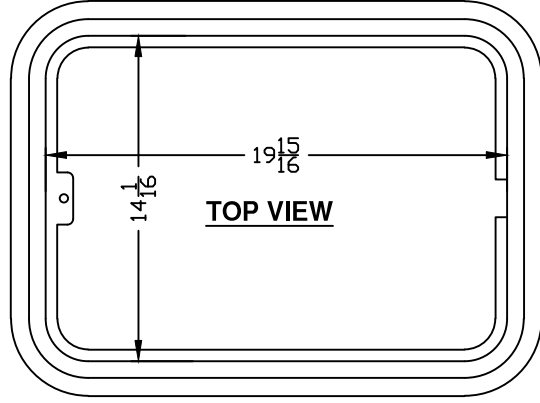

TOP VIEW

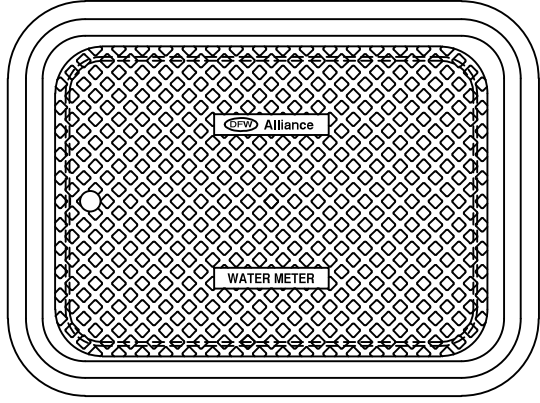

DFW750.6.1

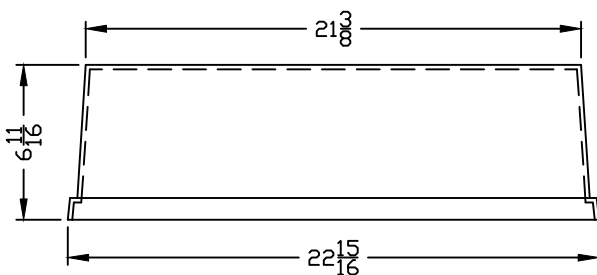

DFW750.6.BODY

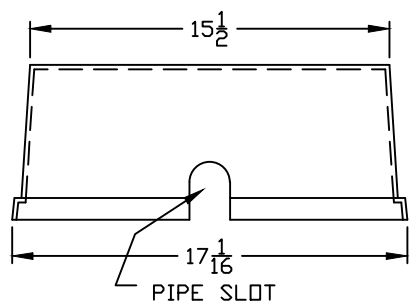

PIPE SLOT

NOTES

- 1) DIM'S ± 1/8" U.N.O.
- 2) LID MATERIAL: P.P.
- 3) BODY MATERIAL: P.P.
- 4) WALL THICKNESS: 3/8" ± 5%

DFW PLASTICS, INC. ENGAGES IN ONGOING RESEARCH AND DEVELOPMENT TO IMPROVE AND ENHANCE ITS PRODUCTS. THEREFORE, DFW PLASTICS, INC. RESERVES THE RIGHT TO CHANGE PRODUCT OR SYSTEM SPECIFICATIONS WITHOUT NOTICE.



DFW PLASTICS, INC.
PO BOX 648
BEDFORD, TEXAS 76095
(817) 439-3600
(817) 439-3700 (f)
www.dfwplasticsinc.com

DFW750.6.1

CREATED: 09/12/2012
UPDATED: 03/19/2014
ACCEPTED: JMc
DRAWN BY: RMc
PLOT SCALE: 1:8