

DFW1730C-1-LID

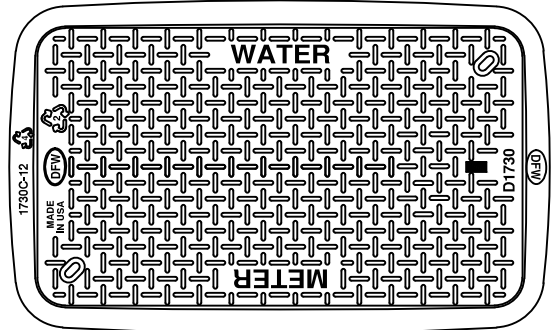

DFW1730C-12-1

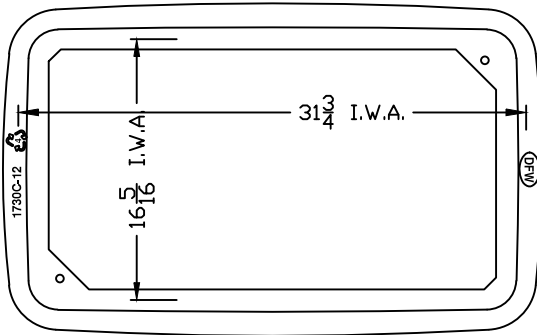
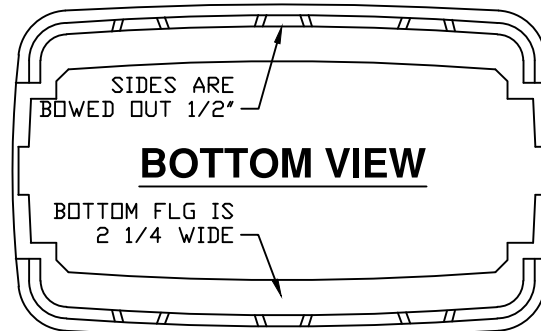
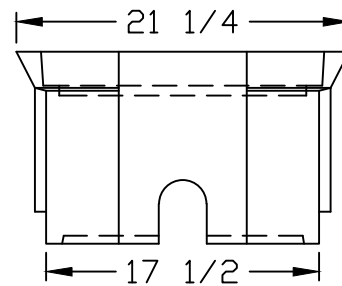
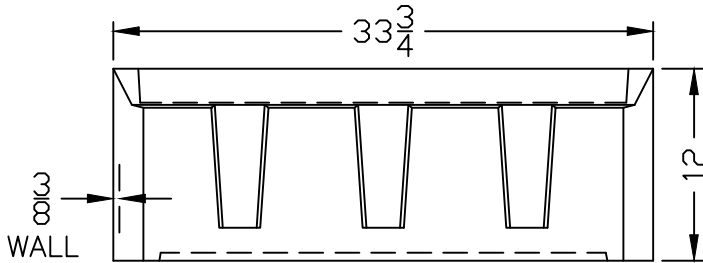

| LID KEY | |
|---------|-------------|
| 1 | BLACK COLOR |

DFW1730C-12-BODY

NOTES

- 1) DIM'S ± 1/8" U.N.O.
- 2) LID MATERIAL: HDPE
- 3) BODY MATERIAL: LLDPE
- 4) WALL THICKNESS: 3/8" ± 5%
- 5) SNAP LOCK POCKET WILL RECEIVE AMR/AMI DEVICE ENDPOINT. SNAP LOCK SLOT IS 1.80" ± .015" TO ALLOW FOR A FINGER FORCE INSTALL. POCKET HEIGHT IS 15/16" FOR MIN 1/8" AIR GAP.

DFW PLASTICS, INC. ENGAGES IN ONGOING RESEARCH AND DEVELOPMENT TO IMPROVE AND ENHANCE ITS PRODUCTS. THEREFORE, DFW PLASTICS, INC. RESERVES THE RIGHT TO CHANGE PRODUCT OR SYSTEM SPECIFICATIONS WITHOUT NOTICE.



DFW PLASTICS, INC.
PO BOX 648
BEDFORD, TEXAS 76095
(817) 439-3600
(817) 439-3700 (f)
www.dfwplasticsinc.com

DFW1730C-12-1

| |
|---------------------|
| CREATED: 03/03/2014 |
| UPDATED: 03/03/2014 |
| ACCEPTED: JMc |
| DRAWN BY: RMc |
| PLOT SCALE: 1:12 |